

Installation and operating instructions for R+W Torque Limiting couplings: Series SK



Please carefully and completely read the following installation, operation and maintenance procedures for the R+W torque limiting couplings. Failure to comply with these procedures may result in poor performance and/or the failure of the coupling.

Installation of the couplings should be performed by a qualified technician.

General functioning



Function:

R+W torque limiting couplings are ball detent style overload couplings. They protect drive and driven mechanical components from damage associated with torque overloads. Backlash free torque transmission is accomplished by a series of steel balls (4) nested in hardened detents (5). See figure 1. Disc springs push against an actuation ring (3) keeping the balls nested. The disengagement torque is adjustable by means of an adjustment ring (1). In the event of an overload, the actuation ring moves axially allowing the balls to come out of the detents separating the drive and driven elements. The movement of the actuation ring can be sensed by means of a mechanical switch or proximity sensor triggering the drive to shut down.

Single-position / Multi-position

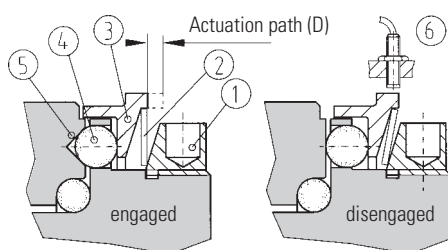

Figure 1

In a torque overload, for the single-position design (standard) and multi-position design, the spring disengages to allow the balls to come out of their detents separating the drive and driven elements. Very low residual spring pressure remains so that the coupling will re-engage once the torque is reduced below the overload setting. See diagram 1 too.



CAUTION: Re-engagement may only be effected at low speed.

Re-engagement of the Full-disengage design

The R+W full-disengage torque limiting coupling can be re-engaged in six different positions or every 60 degrees with low "press-in" force (E). See Table 2. Marks on the actuation ring and body (13) of the coupling must line up and indicate the re-engagement points.



CAUTION: Re-engagement should only be performed when the coupling is still and not rotating!

Full-disengage

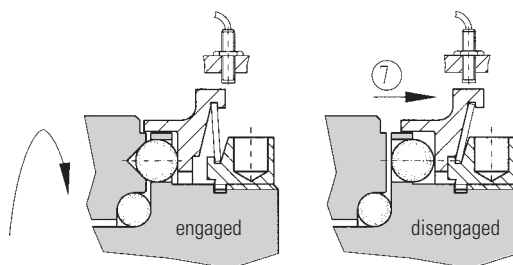

Figure 2

With this design, when a torque overload is detected, the disc spring completely flips over and places no residual spring pressure on the actuation ring. The drive and driven elements are completely separated.



Note:

Re-engagement of the coupling is not automatic and must be performed manually (Figure 3).

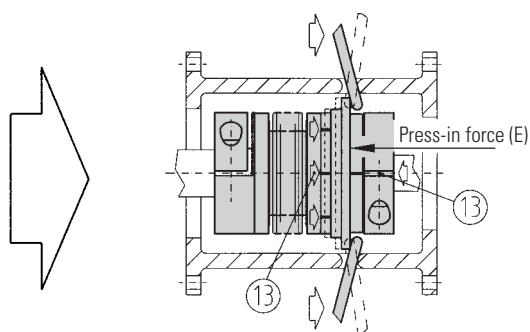

Figure 3

Transport

R+W couplings are delivered ready for installation. After incoming inspection the coupling should be stored in its original packaging until it is ready for installation. A copy of this installation, operation, and maintenance manual should be kept with the coupling.

Safety alert



Safety alert

Rotating couplings can be very dangerous. Proper guarding should be in place at all times and is the responsibility of the machine builder, user or operator. Do not approach or touch a coupling while it is rotating. Make sure that the machine is "locked out" and cannot be accidentally started during installation or maintenance of the coupling.

Manufacturer's declaration

According to EG guidelines for machinery 89/392 EWG Appendix 11B

In the sense of machine guidelines (MR) shaft couplings are no machines, but components for the installation in machines. Their putting into operation is subject to the fulfillment of all requirements of machine guidelines by or after integration in the final product.

Mounting preparation

All mounting surfaces including shafts, bores, keys, and key ways, must be clean and free of burrs, nicks, or dents. Inspect shaft diameters; coupling bore diameters, key and key-way dimensions and tolerances. All R+W coupling bores are machined to ISO tolerance H7. Clearances between shaft and hub bores are maintained to 0.01 and 0.05 mm. A light coating of oil is recommended to ease the mounting process and will not affect the clamping force of the hub.



CAUTION:

Do not use sliding grease, or oils and grease with molybdenum disulfide or other high-pressure additives.

Mounting drive elements to SK 1 couplings

Series	Belt pre-tensioning force max. (N)	Distance from - to (mm)	Fastenin screws	Tightening torque (Nm)	Fastening screws	Tightening torque (Nm)
2	100	5-8	M3	2	x	x
4,5	200	6-10	M4	2,5	x	x
10	500	6-12	M4	4,5	x	x
15	1400	7-14	M5	8	M4	4
20/30	1800	8-18	M6	12/15	M5	4
40/60	2300	8-18	M8	30/40	M5	7
80/150	3000	12-20	M10	50/70	M6	12
200	3500	12-22	M12	120	M6	14
300	4500	12-23	M12	130	M8	18
500	5600	12-25	M16	200	M8	25
800	8000	14-34	x	x	M10	36
1500	12000	20-42	x	x	M12	70

Table 1

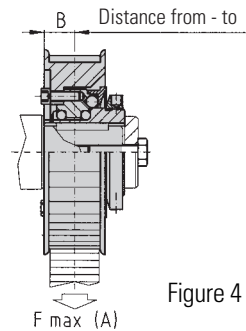

Figure 4

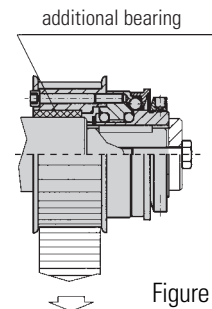

Figure 5

Mounting of the drive element

Center the drive element (i.e. timing belt pulley or gear) onto the connecting flange of the coupling and fasten with screws. If the center of the radial load falls over the middle of the coupling an additional support bearing is not required (figure 4). If the radial load is not centered over the coupling an additional support bearing is required (figure 5). Please observe the maximum allowable radial load for each coupling size as indicated (Table 1). Excess radial load will affect the performance of the coupling.

Mounting and dismounting: Models SK 1 and SKP

SKP with key

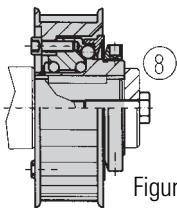

Figure 6

Mounting:

Slide the coupling onto the shaft. Lock it in position, with an end plate (8) for example. Figure 6.

Dismounting:

Remove the end plate and slide the coupling off the shaft using an appropriate tool.

SK 1 with clamping hub

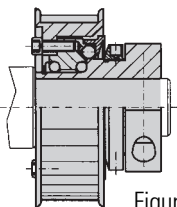

Figure 7

Mounting:

Slide the coupling onto the shaft to the proper axial position. Using a torque wrench tighten the clamp screw to the proper tightening torque as indicated in Table 1.

Dismounting:

Simply loosen the clamp screw and remove the coupling.

SK 1 with tapered bushing

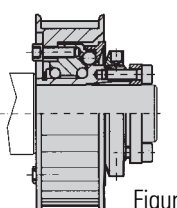

Figure 8

Mounting:

Slide the coupling onto the shaft to the proper axial position. Using a torque wrench, uniformly tighten the clamping screws using a cross-wise tightening pattern until all the clamping screws are evenly tightened to the correct tightening torque as given in Table 1. While tightening the coupling may move slightly towards the tapered bushing.

Dismounting:

Loosen the clamping screw. Insert the three jack screws into the taped holes on the tapered segment apply even pressure to remove the tapered segment. Remove the coupling.



CAUTION: Further tightening of the clamping screws may destroy the tapered bushing connection.

NOTE: Prior to reassembly make sure that the jack-screws are raised to their original position.

Mounting and dismounting: Models SK 2 / 3 / 5

SK 2 with clamping hub

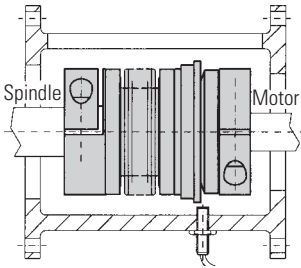

Figure 9

SK 3 with tapered bushing

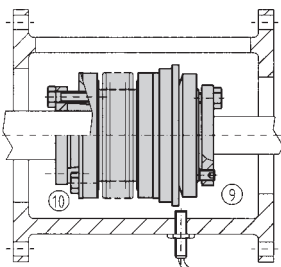

Figure 10

SK 5 with press-fit tapered bushings

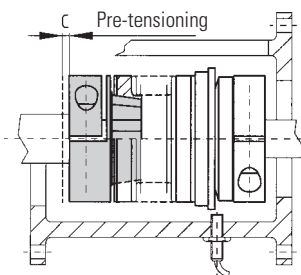

Figure 11

Mounting:

Prior to mounting make sure that the shaft to be connected do not exceed the angular or lateral misalignment limits for the coupling size to be used. This data can be found in the catalog. Slide the coupling on the first shaft end to the proper axial position. Using a torque wrench, tighten the clamp screw to the correct tightening torque as indicated in Table 1. Insert the second shaft into the other end of the coupling to the proper axial position. Make sure that the coupling is free of any axial forces before tightening. Tighten the clamp screw as above using a torque wrench.

Mounting:

Prior to mounting make sure that the shaft to be connected do not exceed the angular or lateral misalignment limits for the coupling size to be used. This data can be found in the catalog. Slide the coupling onto the first shaft to the proper axial position. Using a torque wrench, uniformly tighten the clamping screws using a cross-wise tightening pattern until all the clamping screws are evenly tightened to the correct tightening torque as given in Table 1.



CAUTION: Further tightening of the clamp screws may destroy the tapered bushing connection.

Mounting:

Prior to mounting it is necessary to consider the overall length of the assembled coupling. The press-fit coupling requires a specific pre-tensioning (C) between the two coupling halves to ensure backlash free operation. Mount the "female" coupling half containing the bellow onto the first shaft end to the proper axial position. Using a torque wrench tighten the clamp screw to the proper tightening torque. Mount the "male" coupling segment onto the second shaft end. The proper axial position is when the two couplings come together and coupling is compressed by the proper pre-tension distance (C). See Table 2. When the coupling segment is properly positioned tighten the clamp screw to the proper torque.

Dismounting:

Simply loosen the clamp screw and remove the coupling.

Dismounting:

Loosen the clamping screws. Use the three jackscrews conveniently mounted in the taper segment to evenly back out the tapered segment. Remove the coupling.



CAUTION:

Prior to reassembly make sure that the jackscrews are raised to their original position.

Dismounting:

Pull the coupling apart. Simply loosen the clamp screws and remove the coupling from the shaft.

Axial misalignment

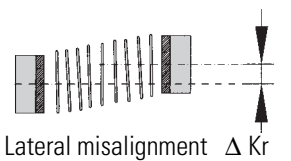

Lateral misalignment ΔK_r

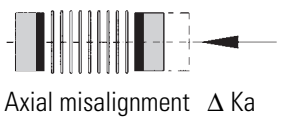

Axial misalignment ΔK_a

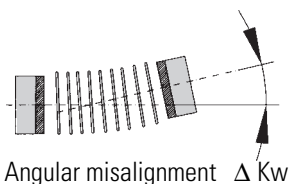

Angular misalignment ΔK_w

Figure 12

Maximum shaft misalignment

In addition to torque overload protection R+W torque limiters combined with a metal bellow compensate for lateral, axial and angular misalignment. Table 2 contains the maximum allowable values for each axis of misalignment for the different size couplings. It is important to remain within these limits to ensure maximum life and proper operation of the coupling.

Series	Lateral misalignment x/x (mm)		Axial misalignment x/x (mm)		Angular x/x (Grad)		Pre-tensioning (SK 5) (mm)	
	ΔK_r	ΔK_a	ΔK_w	C	D	E	Engagement path (full disengagement design) (mm)	Engagement force approx. (N)
2	0,15/0,20	1/2	1/1,5	0,2-0,7	0,8	8-15		
4,5	0,20/0,25	1/2	1/1,5	0,2-0,7	0,8	10-20		
10	0,20/0,30	1/2	1/1,5	0,2-1,0	1,2	15-30		
15	0,15/0,20	1/2	1/1,5	0,2-1,0	1,5	20-40		
20/30	0,20/0,25	1/2	1/1,5	0,3-1,5	1,5	25-50		
40/60	0,20/0,25	1,5/2	1/1,5	0,5-1,5	1,7	30-60		
80/150	0,20/0,25	2/3	1/1,5	0,5-1,0	1,9	35-70		
200	0,25/0,30	2/3	1,5/2	x	2,2	35-70		
300	0,25/0,30	2,5/3,5	1,5/2	0,5-1,5	2,2	50-100		
500	0,30/0,35	2,5/3,5	2/2,5	0,5-2,0	2,2	60-120		
800	0,35	3,5	2,5	x	2,2	x		
1500	0,35	3,5	2,5	x	3	x		

Table 2

x/x First values are for bellows with 4-5 corrugations.
Second values are for bellows with 6-8 corrugations.



CAUTION: Exact alignment of the R+W metal bellow coupling considerably increases the service life of the coupling. Reducing or eliminating lateral misalignment eliminates the radial loading of the adjacent bearings, increasing service life and reducing heat. For drives running at high speed it is recommended to align the coupling with a dial indicator.

Emergency switch function

Mechanical switch (PART No. 618.6740.425)

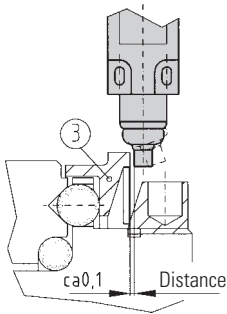
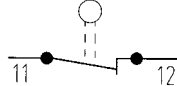

Figure 13

Technical Data

Max. Voltage:	500 V AC
Max. Permanent current:	10 A
Protection type:	IP 65
Type of contact:	Opener
Ambient temperature:	-30°C to +80°C
Confirmation:	(metal)

Switch symbol



Proximity switch (PART No. 650.2703.1)

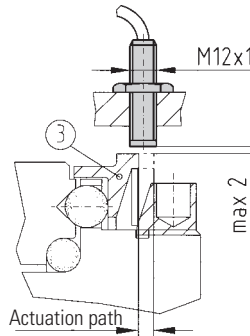
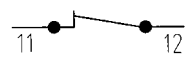

Figure 14

Technical Data

Voltage range:	10 to 30 V DC
Initial current max.:	200 mA
Switch frequency:	800 Hz
Temperature range:	-25°C to +70°C
Protection type:	IP 67
Switching type:	PNP opener
Switch distance:	max. 2 mm

Switch symbol



The axial movement of the actuation ring (1) can be sensed by either a mechanical switch or a proximity sensor. The distance the actuation ring moves is given in Table 2 and is important for the selection of the appropriate sensing device. Mount the sensing device on a solid support keeping the distance shown in figure 13.



Note! Test the switch prior to the delivery of a machine using this device.

Disengagement torque setting

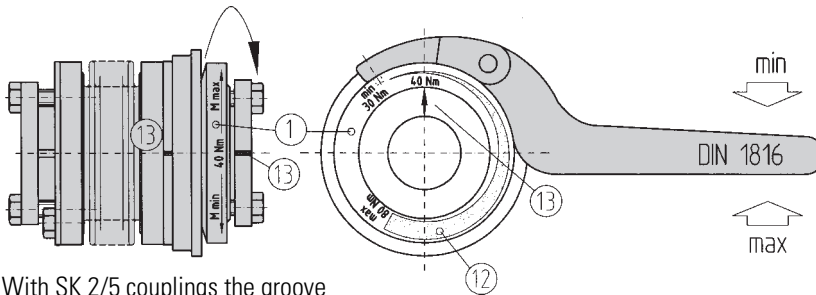
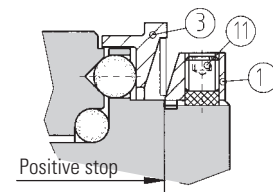

Figure 15

With SK 2/5 couplings the groove of the clamping hub serves as a marking (3)



- 1 adjusting nut
- 11 fastening screw
- 3 steel actuation ring
- 12 adjustment range
- 13 marking

Figure 16

R+W torque limiters are factory set to the customer specified disengagement torque, which is marked onto the coupling. The adjustment range (min/max) is also marked on the adjustment ring. The customer can adjust the disengagement torque as long as it falls into the range indicated on the adjustment ring.



The adjustment range may not be left during setting.

To adjust the disengagement torque, loosen the locking screws (11) and rotate the adjustment ring using a spanner wrench to the desired new setting. Tighten the locking screws and test the coupling.



CAUTION: R+W torque limiters incorporate disc springs that exhibit a special spring characteristic. It is important to stay in the max-min range of the coupling.

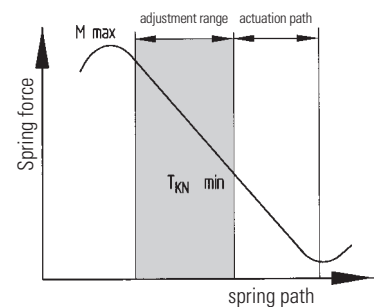

Diagram 1

Maintenance



R+W torque limiters are maintenance free as long as they are properly mounted and the maximum misalignment and radial load values are not exceeded. The internal components are permanently greased for lifetime lubrication.

CAUTION: Disassembly of the coupling will void the warranty.

R+W
COUPLING TECHNOLOGY

R+W Antriebselemente GmbH
Alexander-Wiegand-Str. 8 · 63911 Klingenberg
Tel. +49-(0)93 72 - 98 64-0 · Fax +49-(0)93 72 - 98 64 20
info@rw-kupplungen.de · http://www.rw-couplings.com

The above-mentioned information is based on our present knowledge and experiences and does not free the user of his own regular checks. A legally binding guarantee is not given even in regard to protection rights of Third parties.