

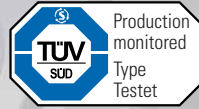

single-position
multi-position
load holding
full disengagement



MODEL SK5



BACKLASH FREE TORQUE LIMITER

press-fit version, with clamping hub

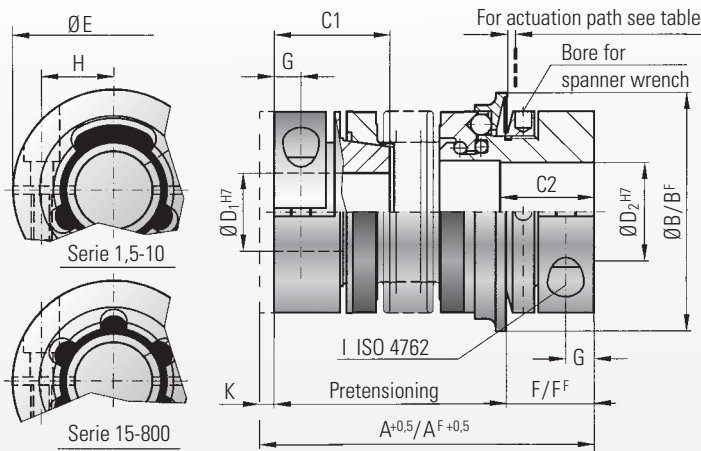

Optional sealed version for wash down and foodservice application. See page 16.

Material:

Bellows made of highly elastic stainless steel
Torque limiter section: High strength hardened steel

Clamping hubs:

up to series 80 aluminium from series up 150 steel

Design:

With a single radial clamping screw per hub

Temperature range:

-30° C to +100° C

Backlash:

Absolutely backlash free as a result of the frictional clamp connection and the patented R+W principle

Service life:

These couplings are maintenance free and have extreme service life as long as the performance limits are not exceeded.

Fit tolerance:

Tolerance between hub and shaft 0.01-0.05 mm

Ordering specifications:

Page 11

Model SK 5		Series												
		1.5	2	4.5	10	15	30	60	80	150	300	500	800	
Adjustment range available from - to (approx. values) (Nm)	T _{KN}	0.1-0.6 0.4-1 0.8-1.5	0.2-1.5 or 0.5-2	1-3 or 3-6	2-6 or 4-12	5-10 or 8-20	10-25 or 20-40	10-30 or 25-80	20-70 or 30-90	20-70 or 45-150	100-200 150-240 200-320	80-200 200-350 300-500	400-650 500-800 650-850	
Adjustment range available from - to (approx. values) (full disengagement) (Nm)	T _{KN}	0.3-0.8 or 0.6-1.3	0.5-2	2.5-4.5	2-5 or 5-10	7-15	8-20 or 16-30	20-40 or 30-60	20-60 or 40-80	80-150	120-200 or 160-300	60-150 100-300 250-500	200-400 or 450-800	
Overall length +0,5 inserted (mm)	A	44	48 54	60 68	70 79	76 83	89 97	105 115	115 127	116 128	143 157	166 180	196	
Overall length +0,5 inserted (full disengagement) (mm)	A ^F	44	48 54	60 68	70 79	76 83	89 97	105 115	117 129	118 130	146 160	170 184	207	
Actuation ring Ø (mm)	B	23	29	35	45	55	65	73	92	92	120	135	152	
Actuation ring Ø (full disengagement) (mm)	B ^F	24	32	42	51.5	62	70	83	98	98	132	155	177	
Fit length C ₁ /C ₂ (mm)	C ₁ /C ₂	14 11	16/13	19/16	21/16	28/22	33/27	39/31	43/35	43/35	52/42	61/52	74/48	
Inner diameter from Ø to Ø H7 (mm)	D ₁	3-8	4-12	5-16	5-20	8-22	10-25	12-32	14-38	14-38	30-56	35-60	40-62	
Outer diameter from Ø to Ø H7 (mm)	D ₂	3-8	4-12	5-14	5-20	8-26	10-30	12-32	14-42	14-42	30-60	35-60	40-75	
Outer diameter of coupling (mm)	E	19	25	32	40	49	55	66	81	81	110	123	134	
Distance (mm)	F	12	13	15	17	19	24	28	31	31	35	45	50	
Distance (full disengagement) (mm)	F ^F	11.5	12	14	16	19	22	29	31	30	36	43	54	
Distance (mm)	G	3.5	4	5	5	6.5	7.5	9.5	11	11	13	17	18	
Distance between centers (mm)	H	6	8	10	15	17	19	23	27	27	39	41	2x48	
ISO 4762 screws	I	M2.5	M3	M4	M4	M5	M6	M8	M10	M10	M12	M16	2xM16	
Tightening torque (Nm)	I	1	2	4	4.5	8	15	40	50	70	130	200	250	
Pretensioning, approx. (N)	K	0.1 to 0.5	0.2 to 0.7	0.2 to 0.7	0.2 to 1.0	0.2 to 1.0	0.5 to 1.0	0.5 to 1.0	0.5 to 1.0	0.5 to 1.0	0.5 to 1.5	0.5 to 2.0	0.5 to 2.0	
Axial recovery of coupling max. (N)		4	8 5	15 10	25 30	20 12	50 30	70 45	48 32	82 52	157 106	140 96	200	
Approx. weight (kg)		0.038	0.07	0.2	0.3	0.4	0.6	1.4	2	2.4	5.9	9.6	15	
Moment of inertia (10 ⁻³ kgm ²)	J _{ges}	0.01	0.01 0.01	0.02 0.02	0.06 0.07	0.10 0.15	0.27 0.32	0.75 0.80	1.80 1.90	2.50 2.80	6.50 7.00	13.0 17.0	50	
Torsional stiffness (10 ³ Nm/rad)	C _T	0.7	1.2 1.3	7 5	8 7	12 10	18 16	40 31	68 45	90 60	220 190	260 250	390	
Lateral misalignment max. (mm)		0.15	0.15 0.20	0.20 0.25	0.20 0.30	0.15 0.20	0.20 0.25	0.20 0.25	0.20 0.25	0.20 0.25	0.25 0.30	0.30 0.35	0.35	
Angular misalignment max. (degrees)		1	1 1.5	1.5 2	1.5 2	1 1.5	1 1.5	1 1.5	1 1.5	1 1.5	1.5 2	2 2.5	2.5	
Lateral spring stiffness (N/mm)		70	40 30	290 45	280 145	475 137	900 270	1200 420	920 290	1550 435	3750 1050	2500 840	2000	
Actuation path (mm)		0.7	0.8	0.8	1.2	1.5	1.5	1.7	1.9	1.9	2.2	2.2	2.2	

A^F, B^F, F^F = Full disengagement version

optional
stainless
steel

single-position
multi-position
load holding
full disengagement

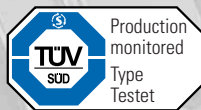

press-fit version, with clamping hub

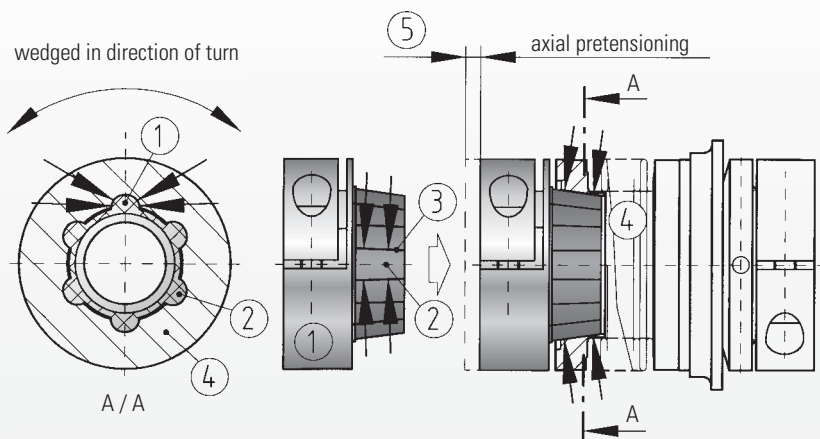

Design details

Six self-centering, tapered drive projections (2) have been formed into the taper segment, which has been molded onto an aluminium hub (1).

The six projections are configured conically in a longitudinal direction (3). The mating-piece consists of a metal bellows with a tapered female element (4).

Absolutely backlash-free torque transmission is ensured due to the axial pretensioning (5) of the metal bellows during mounting. This slight pretensioning has no negative influence on the operation of the metal bellows or on the shaft bearing.

Possible applications for backlash-free, press-fit torque limiter SK 5

1 Applications with limited accessibility. The dismantling of a single-piece coupling is too labor intensive.

2 The **press fit design** allows the motor or gearbox unit to be removed by simply pulling it out when servicing is required.

Dismounting the coupling is possible **without loosening** the hub fastening screws. Therefore, clamping screw access holes are not required.

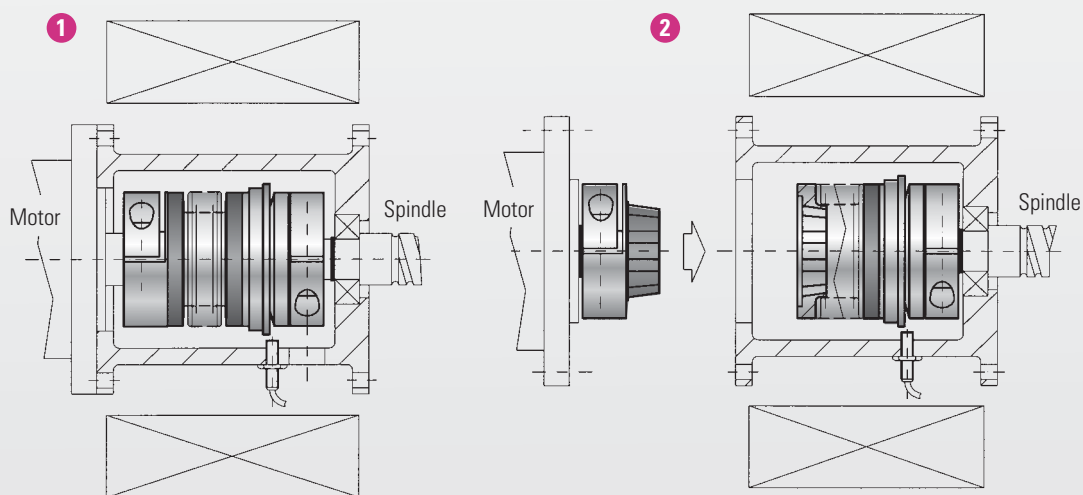

Ordering specifications

SK2 / 60 / 102 / D / 16 / 19 / 25/10-30/XX

Required information for models SK 2, SK 3 and SK 5

- Model
- Series
- Overall length (mm)
- Version
- Bore Ø D1 H7
- Bore Ø D2 H7
- Disengagement torque (Nm)
- Adjustment range (Nm)
- e.g. stainless steel

Possible versions:

- W = single position
- D = multi position
- G = Load holding
- F = Full disengagement