



MODEL MK5

TECHNICAL SPECIFICATIONS



Press-fit precision metal bellows couplings

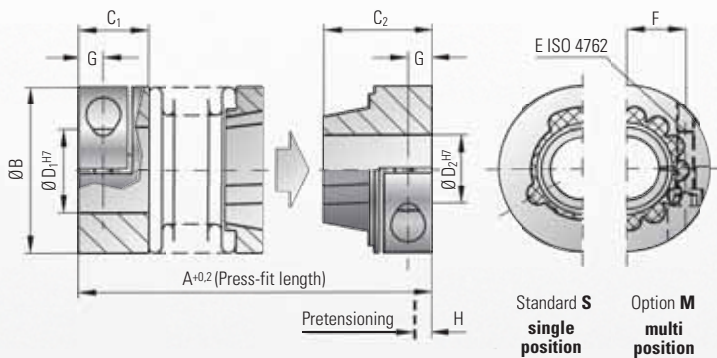

Properties:

- electrically insulated
- no wear
- easy mounting and dismantling
- absolutely backlash-free and torsionally rigid
- low moment of inertia
- compensates for 3-axis of misalignment

Material:

Bellows made of highly flexible high-grade stainless steel, the clamping hubs and tapered female segment on the bellows face are aluminium. Tapered segment on the hub face: glass-fiber reinforced plastic deposited onto an aluminium hub.

Design:

With a single radial clamping screw per hub ISO 4762. Backlash-free, blind mate press-fit connection

Temperature range:

-30° to +110° C (3,6 F to 230 F)

Speed:

Up to 10,000 rpm, over 10,000 rpm available with balanced version.

Service life:

These couplings have an infinite life and are maintenance-free if the technical ratings are not exceeded.

Fit tolerance:

On the hub/shaft connection 0.01 to 0.05 mm.

Non-standard applications:

Custom designs with varied tolerances, keyways, non-standard material and bellows are available upon request.

Ordering example

MK5 / 20 / 37 / 6 / 10 / XX

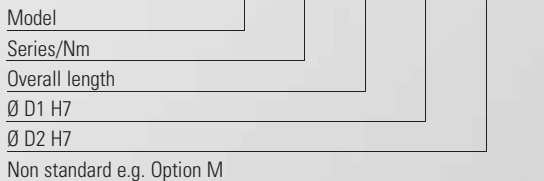

Model MK 5		Series											
		5			15		20			45		100	
Rated torque (Nm)	T _{KN}	0.5			1.5		2			4.5		10	
Overall length without any pretensioning (mm)	A	27	30	33	34	39	37	43	46	49	57	55	65
Outer diameter (mm)	B	15			19		25			32		40	
Fit length (mm)	C ₁	9			11		13			16		16	
Fit length (mm)	C ₂	12			14		16			20		21.5	
Non-standard bore from Ø to Ø H7 (mm)	D _{1/2}	3-6.35			3-8		3-12.7			5-16		5-20 (D ₁ -24)	
Standard bore H7 (mm)	D _{1/2}	6			6		6/10			10		10	
Screws ISO 4762	E	M2			M2.5		M3			M4		M4	
Tightening torque of the assembly screws (Nm)	E	0.43			0.85		2.3			4		4.5	
Distance between centers (mm)	F	4.5			6		8			10		15	
Distance (mm)	G	3			3.5		4			5		5	
Pretensioning approx. (mm)	H	0.4			0.5		0.5			0.7		1	
Axial recovery force of coupling (N)		5	3	2	4	3	3	4	3	15	10	33	46
Mass moment of inertia (gcm ²)	J _{ges}	3.0	3.2	3.5	9.0	10	28	30	33	110	120	220	230
Torsional stiffness (Nm/rad)	C _T	280	210	170	750	700	1200	1300	1200	7000	5000	9050	8800
axial	Max. values	0.4	0.5	0.6	0.5	0.7	0.5	0.6	0.7	0.7	1	1	1.2
lateral		0.15	0.2	0.25	0.15	0.2	0.15	0.2	0.25	0.2	0.25	0.2	0.3
angular		1	1.5	2	1.5	1.5	1.5	1.5	2	1.5	2	1.5	2