

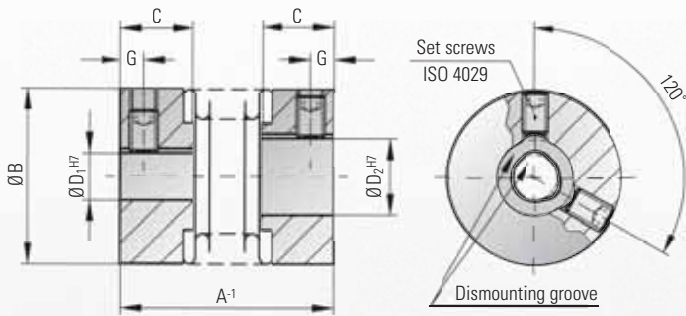

MODEL MK1

TECHNICAL SPECIFICATIONS



common solutions:



Ordering example

MK1 / 5 / 26 / 4 / 5 / XX

Model
Series/Nm
Overall length
Ø D1 H7
Ø D2 H7
Non standard



with radial clamping screw

Properties:

- backlash-free and torsionally rigid
- low-cost design
- low moment of inertia
- compensates for 3-axis of misalignment
- a mounting groove or flattening of the shaft is not required due to the integrated dismounting groove

Material:

Bellows are made of highly flexible high-grade stainless steel, hubs from aluminium.

Design:

Hubs with DIN 916 radial set screw and **integral dismounting groove**.

Temperature range:

-30 to +110° C (3.6 F to 230),

Speeds:

Up to 20,000 rpm, in excess of 20,000 rpm available with balanced version

Service life:

These couplings have an infinite service life, and are maintenance free, if the technical limits are not exceeded.

Fit tolerance:

On the hub/shaft connection 0.01 to 0.08 mm.

Non-standard application:

Custom designs with varied tolerances, keyways, non-standard material and bellows are available upon request.

Model MK 1		Series																	
		0.5		1		5			10			15		20		45		100	
Rated torque (Nm)	T_{KN}	0.05	0.1	0.5			1.0			1.5		2.0		4.5		10			
Overall length (mm)	A	14	20	20	23	26	22	25	28	24	29	26	31	35	37	45	43	53	
Outer diameter (mm)	B	6.5	10	15			15			19		25		32		40			
Fit length of hub (mm)	C	4	5	6.5			6.5			7.5		11		13		15			
Special bores from Ø to Ø H7 (mm)	$D_{1/2}$	1-3	1-5	3-9			3-9			3-12		3-16		6-22		6-28			
Standard bore H7 (mm)	$D_{1/2}$	2	3	6			6			6/10		6/10		10		10			
Clamping screw ISO 4029		1xM2	1xM2.5	1xM3			1xM3			2xM3		2xM4		2xM5		2xM6			
Tightening torque of the assembly screws (Nm)	E	0.35	0.75	1.3			1.3			1.3		2.5		4		6			
Distance (mm)	G	1.5	1.8	2			2			2		2.5		3.5		4			
Mass moment of inertia (gcm ²)	J	0.1	0.4	1.1	1.2	1.3	1.3	1.8	2	4.7	5.5	15	18	20	65	70	180	220	
Weight (g)		1	5	6	6	6	6	7	8	12	14	22	24	26	54	58	106	114	
Torsional stiffness (Nm/rad)	C_T	50	70	280	210	170	510	380	320	750	700	1200	1300	1200	7000	5000	9050	8800	
axial	Max. values	0.4		0.4	0.4	0.5	0.6	0.4	0.5	0.6	0.5	0.7	0.5	0.6	0.7	0.7	1	1	1.2
lateral		0.1		0.15	0.15	0.2	0.25	0.15	0.2	0.25	0.15	0.2	0.15	0.2	0.25	0.2	0.25	0.2	0.3
angular		1		1	1	1.5	2	1	1.5	2	1.5	1.5	1.5	1.5	2	1.5	2	1.5	2

Integral dismounting groove from bore diameter 4 mm and larger. (1 Nm = 8.85 in lbs)