

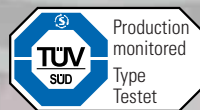

single-position
multi-position
load holding
full disengagement



MODEL ES2



BACKLASH FREE TORQUE LIMITERS

with clamping hubs

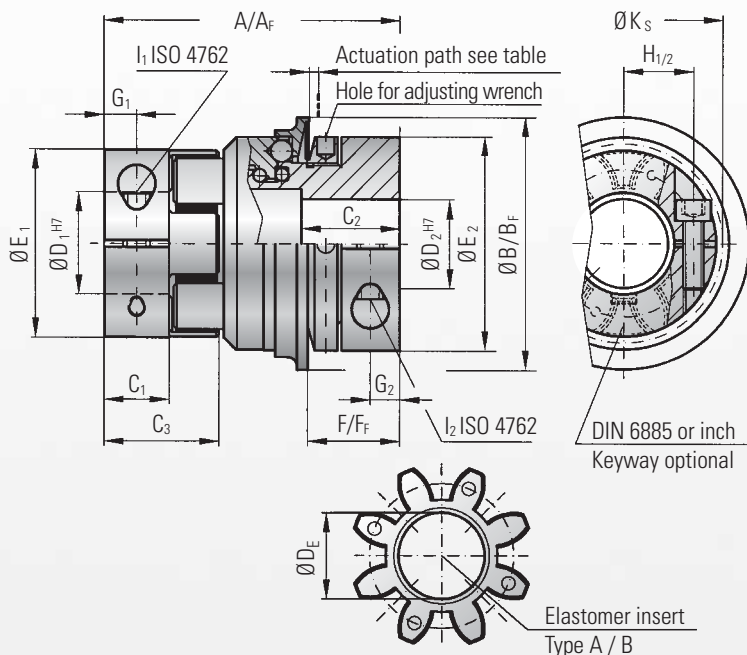

Properties:

- reliable torque overload protection
- short compact design
- backlash-free due to patented R+W design
- disengagement within msec.
- large actuation path when disengaging
- electrically insulating
- press-fit design

Material:

Torque limiter: high strength hardened steel with rust protected surface (oxidized)
Clamping hub D_1 : up to series 450 high strength aluminum, from series 800 and up steel
Clamping hub D_2 : up to series 60 high strength aluminum, from series 150 and up steel
Elastomer insert: precision molded, wear resistant, and thermally stable polymer

Design:

Two coupling hubs are concentrically machined with concave driving jaws
One side with an integrated torque limiter
The torque limiter is available in single position, multi position, load holding or full-disengagement versions.

Tolerance:

On the hub/shaft connection 0.01 to 0.05 mm

W = Single position re-engagement

- After the overload has been eliminated, the coupling will automatically reengage precisely 360° from the original disengagement position
- Achievement of the precise synchronus re-engagement due to patented R+W design
- Signal at overload with mechanical switch or proximity sensor

D = Multi position re-engagement

- Coupling re-engages at multiple set angular intervals.
- Immediate availability of the machine as soon as the overload has been eliminated.
- Signal at overload with mechanical switch or proximity sensor
- Standard engagement every 60°
- Engagement at 30, 45, 90 and 120 degrees are optional.

G = Load holding version

- Mechanical overload detection device
- In the event of a torque overload, the drive and driven elements are not fully separated and are only allowed limited rotation.
- Guaranteed to hold the load and signal an overload.
- Automatic engagement after the torque level has dropped.
- Signal at overload to detect with mechanical switch or proximity sensor.

F = Full disengagement

- Permanent separation of drive and driven loads in the event of a torque overload.
- No residual friction
- Signal at overload
- Rotating elements slow down freely
- Coupling can be re-engaged manually (Engagement every 60°)

Ordering example

ES2 / 10 / A / W / 14 / 12.7 / 8 / 4-12 / XX

Model	ES2
Series	10
Type Elastomer insert	A
Function system	W
Bore ΔD_1 H7	14
Bore ΔD_2 H7	12.7
Disengagement torque	8
Adjustable range	4-12
Non standard e.g. VA-Material	XX

All data is subject to change without notice.

The selection of torque limiters

In general the torque limiters are sized according to the necessary disengagement torque. This torque must exceed the nominal torque of the application.

For more information see page 22.



MODEL ES2

BACKLASH FREE TORQUE LIMITERS

Model ES 2	Series																
	A		B		10		20		60		150		300		450		800
Type (Elastomer insert)																	
Rated torque	9	12	12,5	16	17	21	60	75	160	200	325	405	530	660	950	1100	
Max. torque*	18	24	25	32	34	42	120	150	320	400	650	810	1060	1350	1900	2150	
Adjustment range possible from -to (Nm) (approx. values)	T_{KN}		1-3 or 3-6	2-6 or 4-12	10-25 or 20-40	10-30 or 25-80	20-70 45-150 80-180	100-200 150-240 200-320	80-200 200-350 300-500	400-650 500-800 600-900							
Adjustment range (full disengagement) possible from -to (Nm) (approx. values)	T_{KN}^F		2.5 - 4.5	2-5 or 5-10	8 - 20 or 16 - 30	20 - 40 or 30 - 60	20-60 40-80 80-150	120 - 180 or 180 - 300	60 - 150 100 - 300 250 - 500	200 - 400 or 450 - 800							
Overall length (mm)	A	50	60	86	96	106	140	164	179								
Overall length (full disengagement) (mm)	A _F	50	60	86	96	108	143	168	190								
Outer diameter of actuation ring (mm)	B	35	45	65	73	92	120	135	152								
Outer diameter of actuation ring (mm)	B _F	42	51.5	70	83	98	132	155	177								
Fit length (mm)	C ₁	8	10.3	17	20	21	31	34	46								
Fit length (mm)	C ₂	14	16	27	31	35	42	51	45								
Length of hub (mm)	C ₃	16.7	20.7	31	36	39	52	57	74								
Inner diameter from Ø to Ø H7 (mm)	D ₁	4 - 12.7	5 - 16	8 - 25	12 - 32	19 - 36	20 - 45	28 - 60	35 - 80								
Inner diameter from Ø to Ø H7 (mm)	D ₂	6 - 14	6 - 20	12 - 30	15 - 32	19 - 42	30 - 60	35 - 60	40 - 75								
Inner diameter (Elastomer insert) (mm)	D _E	10.2	14.2	19.2	26.2	29.2	36.2	46.2	60.5								
Diameter of the hub (mm)	E ₁	25	32	42	56	66.5	82	102	136.5								
Diameter of the hub (mm)	E ₂	19	40	55	66	81	110	123	132								
Distance (mm)	F	15	17	24	30	31	35	45	50								
Distance full disengagement (mm)	F _F	14	16	22	29	30	35	43	54								
Distance (mm)	G ₁	4	5	8.5	10	11	15	17.5	23								
Distance (mm)	G ₂	5	5	7.5	9.5	11	13	17	18								
Distance between centers (mm)	H ₁	8	10.5	15	21	24	29	38	50.5								
Screws (ISO 4762/12.9)	I ₁	M3	M4	M5	M6	M8	M10	M12	M16								
Tightening torque of the mounting screw (Nm)	I ₁	2	4.5	8	15	35	70	120	290								
Distance between centers SK-side (mm)	H ₂	10	15	19	23	27	39	41	48								
Screws (ISO 4762/12.9)	I ₂	M4	M4	M6	M8	M10	M12	M16	2x M16								
Tightening torque of the mounting screw (Nm)	I ₂	4	4.5	15	40	70	130	200	250								
Diameter with screwhead (mm)	K _S	25	32	44.5	57	68	85	105	139								
Approx. weight (kg)	J _{ges}	0.2	0.3	0.6	1.0	2.4	5.8	9.3	14.3								
Moment of inertia (10 ⁻³ kgm ²)	J _{ges}	0.02	0.06	0.25	0.7	2.3	11	22	33.5								
Actuation path (mm)		0.8	1.2	1.5	1.7	1.9	2.2	2.2	2.2								

Information about static and dynamic torsional stiffness as well as max. possible misalignment see page 5

1 Nm = 8.85 in lbs

* (Max. transferable torque of the clamping hub see Elastomer Coupling EKH (Page 6))

Mounting instructions

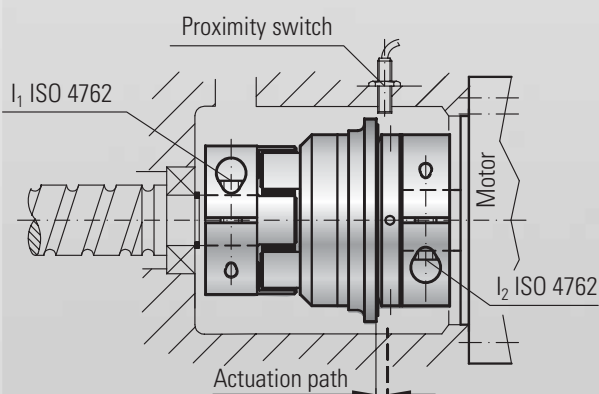

Mounting: Slide the coupling on the shaft ends to the proper axial position. Using a torque wrench, tighten the clamp screws to the correct tightening torque as indicated (in the table page 12)

CAUTION! Both clamping hubs have different screws and different tightening torques.

Dismounting: Simply loosen the clamp screw I1, I2 and remove the safety coupling.

Emergency cut off: The axial path of the actuation ring activates the mechanical switch or the proximity sensor.

CAUTION! Upon assembly, it is absolutely necessary to test the function of the switch 100%



FUNCTION SYSTEMS ES2

BACKLASH FREE TORQUE LIMITERS

R+W torque limiting couplings are ball detent style overload couplings. They protect drive and driven mechanical components from damage associated with torque overloads.

- Backlash free torque transmission is accomplished by a series of steel balls (4) nested in hardened detents (5).
- Disc springs push against an actuation ring (3) keeping the balls nested.
- The disengagement torque is adjustable by means of an adjustment nut (1).
- In the event of an overload, the actuation ring (3) moves axially allowing the balls to come out of the detents separating the drive and driven elements.
- The movement of the actuation ring (3) can be sensed by means of a mechanical switch or proximity sensor (6) triggering the drive to shut down.

Disengagement torque setting

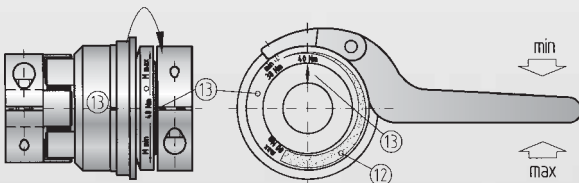

On ES 2 couplings, the slot of the clamping hub serves as a reference point (13).

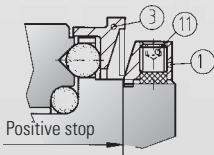

- 1 adjustment nut
- 11 locking screw
- 3 steel actuation ring
- 12 adjustment range
- 13 marking

R+W torque limiters are factory set to the customer specified disengagement torque, which is marked on the coupling. The adjustment range (min/max) is also marked on the adjustment nut (1).

The customer can adjust the disengagement torque as long as it is in the range (12) indicated on the adjustment nut.

The adjustment range must not be exceeded while re-adjusting.

To adjust the disengagement torque, loosen the locking screws (11) and rotate the adjustment ring using a spanner wrench to the desired new setting. Tighten the 3 locking screws (11) and test the coupling.

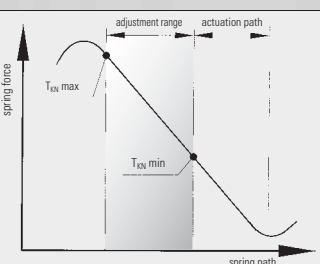

CAUTION:

R+W torque limiters incorporate disc springs that exhibit a special spring characteristic. It is important to stay in the max-min range of the coupling.

Single-position / Multi-position

In a torque overload, with the single-position design (standard) and multi-position design, the spring disengages to allow the balls to come out of their detents, separating the drive and driven elements. Very low residual spring pressure remains so that the coupling will re-engage once the torque is reduced below the overload setting.

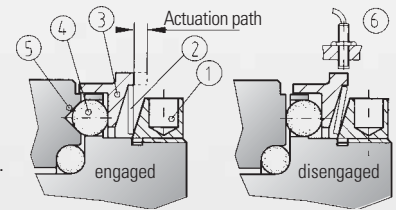

Full-disengage

With this design, when a torque overload is detected, the disc spring completely flips over and places no residual spring pressure on the actuation ring. The drive and driven elements are completely separated.

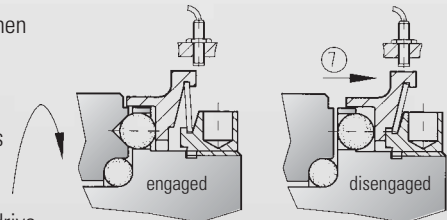

Re-engagement of the coupling is not automatic and must be performed manually (Picture 3a, 3b).

CAUTION:
Re-engagement should only be performed when the coupling stands still and not rotating!

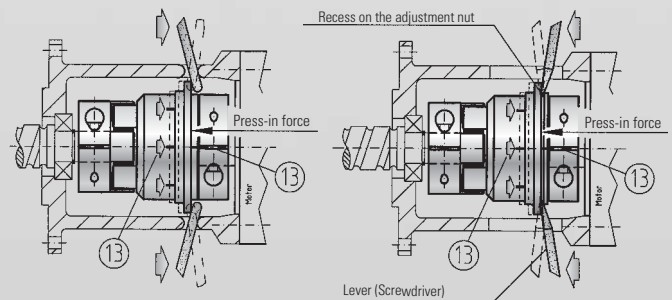

Picture 3a

Picture 3b

The R+W full-disengage torque limiting coupling can be re-engaged in six different positions or every 60 degrees with low „press-in“ force (E). Marks on the actuation ring and body (13) of the coupling must line up and indicate the re-engagement points.

As of size 160 and up the re-engagement can be done with 2 lever which will be supported at a recess on the adjustment nut (picture 3b). Screwdrivers can be used as a lever.