

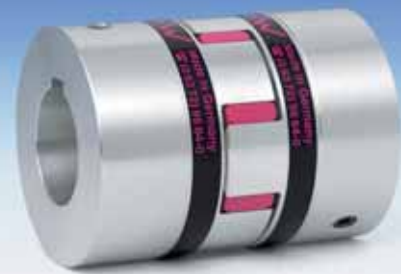

# MODEL EK1

## BACKLASH FREE ELASTOMER COUPLINGS



with keyway connection

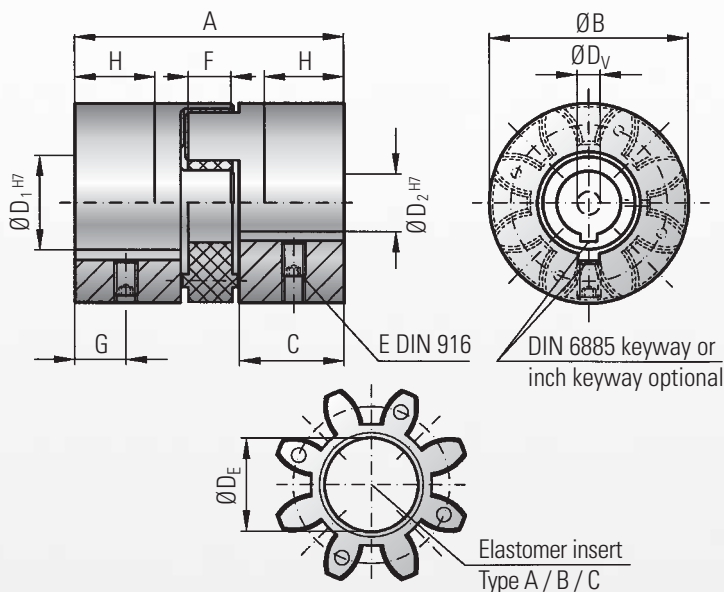

### Properties:

- economically priced
- concentrically machined
- damps vibrations
- electrical insulating
- press-fit design
- low backlash, due to keyway connection

### Material:

Clamping hub: up to series 450 high strength aluminum, from series 800 and up steel  
Elastomer insert: precision molded, wear resistant, and thermally stable polymer

### Design:

Two coupling hubs are concentrically machined with concave driving jaws  
Bore tolerance H7 + keyway + set screw  
DIN 916 or optional pilot bored ( $D_V$ )

### \*Speeds:

Over 10,000 rpm a finely balanced version is available

### Tolerance:

On the hub/shaft connection 0.01 to 0.05 mm

Model EK 1	Series																										
	2			5			10			20			60			150			300			450			800		
Type (Elastomer insert)	A	B	C	A	B	C	A	B	C	A	B	C	A	B	C	A	B	C	A	B	C	A	B	C	A	B	C
Rated torque (Nm) $T_{KN}$	2	2.4	0.5	9	12	2	12.5	16	4	17	21	6	60	75	20	160	200	42	325	405	84	530	660	95	950	1100	240
Max. torque (Nm) $T_{Kmax}$	4	4.8	1	18	24	4	25	32	6	34	42	12	120	150	35	320	400	85	650	810	170	1060	1350	190	1900	2150	400
Overall length (mm) A	20			34			35			66			78			90			114			126			162		
Outer diameter (mm) B	15			25			32			42			56			66.5			82			102			136.5		
Mounting length (mm) C	6.5			12			12			25			30			35			45			50			65		
Inner diameter pilot bored (mm) $D_V$	3			4			6			7			9			14			18			22			29		
Inner diameter range H7 (mm) $D_{1/2}$	3 - 9			6 - 15			6 - 18			8 - 25			12 - 32			19 - 38			20 - 45			28 - 60			32 - 80		
Inner diameter max. (elastomer) (mm) $D_E$	6.2			10.2			14.2			19.2			26.2			29.2			36.2			46.2			60.5		
Set screws (DIN 916) E	see table (depending on bore $\emptyset$ )**																										
Width Elastomer insert (mm) F	5			8			9.5			12			14			15			18			20			25		
Distance (mm) G	3			5			6			9			11			12			15			17			30		
Possible shortening length (mm) H	4			6			6			19			22			26			32			37			43		
Moment of inertia per Hub ( $10^{-3} \text{ kgm}^2$ ) $J_1/J_2$	0.0001			0.001			0.003			0.02			0.06			0.1			0.4			1.1			12		
Approx. weight (kg)	0.008			0.03			0.08			0.15			0.35			0.6			1.1			1.7			11		
Speed* (rpm)	28000			22000			20000			19000			14000			11500			9500			8000			4000		

Information about static and dynamic torsional stiffness as well as max. possible misalignment see page 5

1 Nm = 8.85 in lbs

** Set screws	
$D_1/D_2$	E
- $\emptyset 10$	M3
$\emptyset 11-12$	M4
$\emptyset 13-30$	M5
$\emptyset 31-58$	M8
$\emptyset 59-80$	M10

### ■ Details of pilot bored coupling hubs ( $D_V$ )

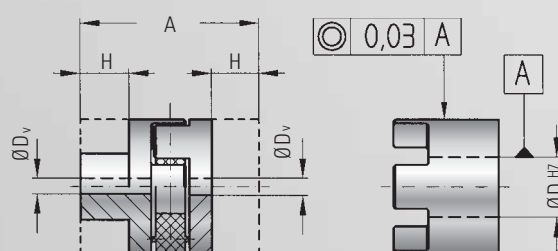

It's critical that modifications of the hub are machined concentrically and perpendicular to the through bore.

EK1 hubs can be modified to customer specifications.  
The coupling hub may be shortened by measurement H.

### Ordering example

EK1 / 60 / A / 19.05 / 24 / XX

Model  
Series  
Type Elastomer insert  
Bore  $\emptyset D_1$  H7  
Bore  $\emptyset D_2$  H7  
Non standard e.g. anodized

All data is subject to change without notice.

boring diameters <  $\emptyset 6$  delivered without keyway.