



MODEL BKL 003

TECHNICAL SPECIFICATIONS



ECOFLEX®

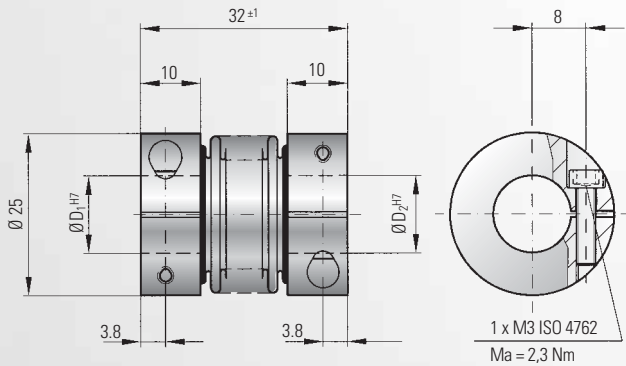

Properties:

- low cost
- backlash-free and torsionally rigid
- compensates for 3-axis of misalignment

Material:

Bellows are made of highly flexible high-grade stainless steel, hubs of aluminium.

Design:

With a single radial clamping screw per hub ISO 4762

Temperature range:

-40 to +200° C (-3.6 to 392 F)

Torque:

3 Nm

Speed:

Up to 10,000 rpm, in excess of 10,000 rpm with balanced version.

Compensation of misalignment:

Lateral misalignment up to 0,2 mm
Axial misalignment up to 1 mm
Angular misalignment up to 2° degree

Ordering example

BKL/003 / 6 /6.35/ XX

Model

Series/Nm

Bore Ø D1 H7

Bore Ø D2 H7

Non standard

ECOFLEX®: The low cost alternative for shaft encoders, potentiometer, stepper motors and small servo drives.

Possible bore diameter

3	4	4.76	5	6	6.35	7	8	9	9.53	10	11	12	12.7
---	---	------	---	---	------	---	---	---	------	----	----	----	------

Bore sizes up to 16 mm available with special hub.

Assembly instructions

Assembly preparation:

During assembly and disassembly the bellows can only be stretched or deformed by 1.5 times the stated catalog values. The shafts and couplings bores must be clean and free of burrs, nicks, and deformations. Double check the shaft and bore dimensions and tolerances to ensure a proper fit. R+W couplings are bored to an ISO H7 tolerance.

The clearance between hub and the bore should be no more than 0.01 to 0.05 mm to ensure a proper fit and clamping strength. A slight film of oil on the shaft will aid in the assembly and disassembly of the coupling without compromising the strength of the coupling.

Important! Oil and grease with molybdenum disulfide or other high pressure additives, as well as sliding greases, should not be used.

Set Screw mounting instructions models MK 1 and MK 4

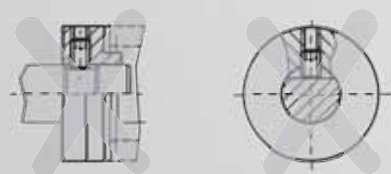
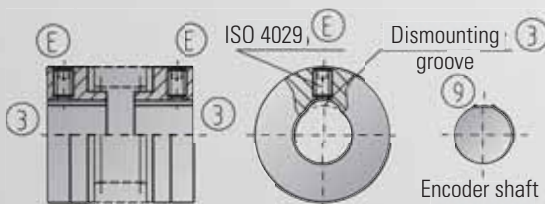

A mounting groove or flattening of the shaft is not required

Assembly:

Slide the coupling onto the shaft of the drive element and position it in place. Tighten the set screw (E) using a torque wrench to the proper torque value listed in the table above. Slide the shaft of the driven element (an encoder for example) into the coupling bore to its proper position. Tighten the second set screw (E) using a torque wrench to the proper torque value.

Series 1 - 10: 1 set screw per hub

Series 15 - 100: 2 set screws per hub set 120 degree apart

Disassembly:

Disassembly is very easy with R+W coupling. Simply loosen the set screw (E) and slide the coupling off the shaft. R+W has incorporated a disassembly groove (3) into the coupling design so that clearance is provided for the set screw "burr" (9).