

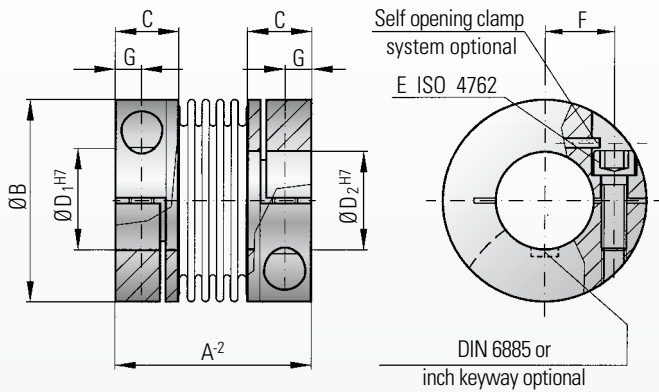

MODEL BKC

TECHNICAL SPECIFICATIONS



compact version

Properties:

- compact design
- easy to mount
- suited for space restricted installations
- low moment of inertia
- economically priced

Material:

Bellows made of highly flexible high-grade stainless steel

Design:

With a single radial clamping screw per hub ISO 4762.

Self opening clamp system optional:
Loosening the clamping screw applies force to the pin, which will force the clamp into the open position for easy mounting and dismounting.

Temperature-range:

-30 to +100° C (3,6 F to 237 F)

Backlash:

Absolutely backlash-free due to frictional clamped connection.

Service life:

These couplings have an infinite life and are maintenance-free if the technical specifications are not exceeded.

Tolerance:

On the hub/shaft connection 0.01 to 0.05 mm.

Non standard:

Custom designs with varied tolerances, keyways, non-standard material and bellows are available upon request.

Ordering example

BKC / 60 / 26 / 22 / XX

Model
Series Nm
Ø D1 H7
Ø D2 H7
non standard

Model BKC			Series					
			15	30	60	150	300	500
Rated torque (Nm)	T_{KN}	15	30	60	150	300	500	
Overall length (mm)	A	48	58	67	78	94	100	
Outer diameter (mm)	B	49	56	66	82	110	123	
Fit length (mm)	C	16.5	21	23	27.5	34	34	
Inner diameter possible from Ø to Ø H7 (mm)	$D_{1/2}$	8-28	12-32	14-35	19-42	24-60	32-75	
ISO 4762 fastening screw	E	M5	M6	M8	M10	M12	M12	
Tightening torque of the fastening screw (Nm)		8	15	40	75	120	125	
Distance between centers (mm)	F	17	20	23	27	39	45	
Distance (mm)	G	6.5	7.5	9.5	11	13	13	
Moment of inertia (10^{-3} kgm ²)	J_{total}	0.05	0.09	0.18	0.65	7.2	8.7	
Hub material (standard) (steel on request)		AL	AL	AL	AL	Steel	Steel	
Approx. weight (kg)		0.13	0.3	0.4	0.8	3.5	4.5	
Torsional stiffness (10^3 Nm/rad)	C_T	23	31	72	141	157	290	
axial	max. Werte	1	1	1.5	2	2	2.5	
lateral		0.15	0.15	0.15	0.15	0.15	0.20	
axial spring stiffness (N/mm)	C_a	30	50	67	77	112	72	
lateral spring stiffness (N/mm)	C_r	315	366	679	960	2940	2200	

max. angular misalignment 1 degree (1 Nm = 8.85 in lbs)