



MODEL BK3

BACKLASH-FREE, TORSIONALLY STIFF METAL BELLOWS COUPLINGS



with tapered conical sleeves

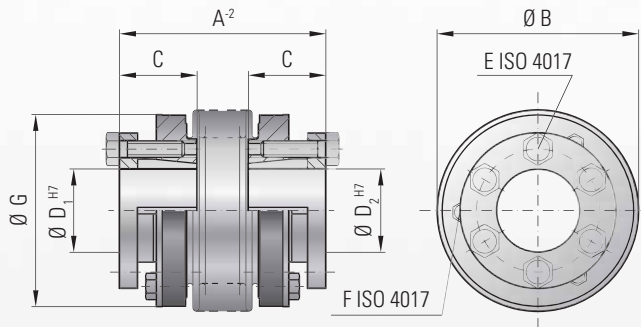

Ordering example

BK3 / 60 / 76 / 20 / 22 / XX

Model
Series / Nm
Overall length
Ø D1 H7
Ø D2 H7
Non standard e.g. stainless steel

Properties:

- high clamping forces
- high degree of operating dependability
- new draw off device suited for space restricted installations

Material:

Bellows made of highly flexible high-grade stainless steel, the hub material is steel.

Design:

With tapered conical sleeves and strong, captive ISO 4017 draw-off screws.

Temperature range:

-30 to +110° C (-22 F to 230 F)

Speeds:

Up to 10,000 rpm, in excess of 10,000 available with a finely balanced version.

Service life:

These couplings are maintenance-free if the technical ratings are not exceeded.

Backlash:

Absolutely backlash-free due to frictional clamp connection.

Brief overloads:

Acceptable up to 1.5 times the value specified.

Tolerance:

On the hub/shaft connection 0.01 to 0.05 mm

Non-standard application:

Custom designs with varied tolerances, keyways, non-standard material, bellows and ATEX designs are available upon request.

Model BK 3		Series																							
		15		30		60		150		200		300		500		800		1500		4000		6000		10000	
Rated torque (Nm)	T_{KN}	15		30		60		150		200		300		500		800		1500		4000		6000		10000	
Overall length (mm)	A^2	48	55	57	65	66	76	75	87	78	90	89	103	97	110	114	141	195	210	217					
Outer diameter of bellows (mm)	B	49		55		66		81		90		110		124		133		157		200		253		303	
Fit length (mm)	C	19		22		27		32		32		41		41		50		61		80		85		92	
Inner diameter from Ø to Ø H7 (mm)	D_1/D_2	10-22		12-23		12-29		15-38		15-44		24-56		24-60		30-60		35-70		50-100		60-140		70-180	
Fastening screws ISO 4017	E	6x M4		6x M5		6x M5		6x M6		6x M6		6x M8		6x M8		6x M10		6x M12		6x M16		6x M16		8x M16	
Tightening torque of the fastening screws (Nm)		4		6		8		12		14		18		25		40		70		120		150		160	
Draw-off screw 3x ISO 4017	F	3x M4		3x M4		3x M5		3x M5		3x M6		3x M6		3x M6		3x M8		6x M8		6x M10		6x M10		8x M10	
Outer diameter of hub (mm)	G	49		55		66		81		90		110		122		116		135		180		246		295	
Moment of inertia (10^3 kgm ²)	J_{total}	0.07	0.08	0.15	0.16	0.39	0.41	1.2	1.6	1.7	2.5	5.1	5.9	9.1	9.9	13.2	34.9	85.5	254	629					
Approx. weight (kg)		0.25		0.4		0.8		1.2		1.8		3		4.2		5.6		8.2		23		32.6		45.5	
Torsional stiffness (10^3 Nm/rad)	C_t	20	15	39	28	76	55	175	110	191	140	450	350	510	500	780	1304	3400	5700	10950					
axial ± (mm)	Max. values	1	2	1	2	1.5	2	2	3	2	3	2.5	3.5	2.5	3.5	3.5	3.5	3.5	3.5	3	3				
lateral ± (mm)		0.15	0.2	0.2	0.25	0.2	0.25	0.2	0.25	0.25	0.3	0.25	0.3	0.3	0.35	0.35	0.35	0.35	0.35	0.4	0.4	0.4			
angular ± (degree)		1	1.5	1	1.5	1	1.5	1	1.5	1	1.5	1	1.5	1	1.5	1.5	1.5	1.5	1.5	1.5	1.5	1.5			
axial spring stiffness (N/mm)	C_a	25	15	50	30	72	48	82	52	90	60	105	71	70	48	100	320	565	1030	985					
lateral spring stiffness (N/mm)	C_l	475	137	900	270	1200	420	1500	435	2040	610	3750	1050	2500	840	2000	3600	6070	19200	21800					

(1Nm $\hat{=}$ 8.85 in lbs)