



MODEL BK2

BACKLASH-FREE, TORSIONALLY STIFF METAL BELLOWS COUPLINGS



with clamping hub

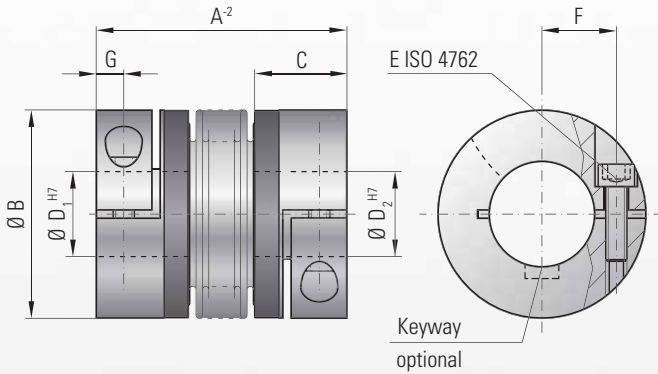

Ordering example

BK2 / 80 / 94 / 20 / 25.4 / XX

Model
Series / Nm
Overall length
Ø D1 H7
Ø D2 H7
Non standard e.g. stainless steel

Properties:

- easy to mount
- suited for space restricted installations
- low moment of inertia

Material:

Bellows made of highly flexible high-grade stainless steel, hub material: see table below

Design:

With a single radial clamping screw per hub ISO 4762. Any imbalance of the clamping hubs is compensated for by balancing bores located on the inside of the hub.

Temperature range:

-30 to +110° C (-22 F to 230 F)

Speeds:

Up to 10,000 rpm, in excess of 10,000 available with a finely balanced version.

Service life:

These couplings are maintenance-free if the technical ratings are not exceeded.

Backlash:

Absolutely backlash-free due to frictional clamp connection.

Brief overloads:

Acceptable up to 1.5 times the value specified.

Tolerance:

On the hub/shaft connection 0.01 to 0.05 mm

Non-standard application:

Custom designs with varied tolerances, keyways, non-standard material, bellows and ATEX designs are available upon request.

Model BK2	Series																				
	15		30		60		80		150		200		300		500		800		1500		
Rated torque (Nm)	T_{KN}	15		30		60		80		150		200		300		500		800		1500	
Overall length (mm)	A^{-2}	59	66	69	77	83	93	94	106	95	107	105	117	111	125	133	146	140		166	
Outer diameter (mm)	B	49		55		66		81		81		90		110		124		134		157	
Fit length (mm)	C	22		27		31		36		36		41		43		51		45		55	
Inner diameter possible from Ø to Ø H7 (mm)	D_1/D_2	8-28		10-30		12-32		14-42		19-42		22-45		24-60		35-60		40-75		50-80	
Fastening screw ISO 4762	E	M5		M6		M8		M10		M10		M12		M12		M16		2xM16		2xM20	
Tightening torque of the fastening screw (Nm)		8		15		40		50		70		120		130		200		250		470	
Distance between centers (mm)	F	17		19		23		27		27		31		39		41		2x48		2x55	
Distance (mm)	G	6.5		7.5		9.5		11		11		12.5		13		16.5		18		22.5	
Moment of inertia (10^{-3} kgm ²)	J_{total}	0.06	0.07	0.12	0.13	0.32	0.35	0.8	0.85	1.9	2	3.2	3.4	7.6	7.9	14.3	14.6	16.2		43	
Hub material (standard) (steel on request)		Al optional steel		Al optional Stahl		Al optional Stahl		Al optional Stahl		steel optional Al		steel optional Al		steel optional Al		steel optional Al		steel		steel	
Approx. weight (kg)		0.16		0.26		0.48		0.8		1.85		2.65		4		6.3		5.7		11.5	
Torsional stiffness (10^3 Nm/rad)	C_T	20	15	39	28	76	55	129	85	175	110	191	140	450	350	510	500	780	1304		
axial	Max. values	± (mm)		1	2	1	2	1.5	2	2	3	2	3	2	3	2.5	3.5	2.5	3.5	3.5	3.5
lateral		± (mm)		0.15	0.2	0.2	0.25	0.2	0.25	0.2	0.25	0.2	0.25	0.25	0.3	0.25	0.3	0.3	0.35	0.35	0.35
angular		± (degree)		1	1.5	1	1.5	1	1.5	1	1.5	1	1.5	1	1.5	1	1.5	1	1.5	1.5	1.5
axial spring stiffness (N/mm)	C_a	25	15	50	30	72	48	48	32	82	52	90	60	105	71	70	48	100	320		
lateral spring stiffness (N/mm)	C_r	475	137	900	270	1200	420	920	290	1550	435	2040	610	3750	1050	2500	840	2000	3600		

(1Nm \approx 8.85 in lbs)

* two screws each hub, 180° apart