



# MODEL BK1

BACKLASH-FREE, TORSIONALLY STIFF METAL BELLOWS COUPLINGS



with flange mounting

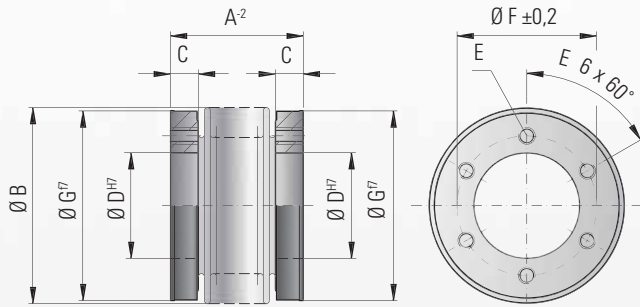

**Properties:**

**Material:**

**Design:**

**Temperature range:**

**Speeds:**

**Service life:**

**Backlash:**

**Brief overloads:**

**Non-standard application:**

- special design application

Bellows made of highly flexible high grade stainless steel, hub material: steel

The hubs have six threaded metric mounting holes, and the ID and OD are concentrically machined to ISO H7 tolerances.

Hubs with custom bore size, mounting threads and bolt circles are available upon request.

-30 to +110° C (-22 F to 230 F)

Up to 10,000 rpm, in excess of 10,000 with finely balanced version.

These couplings are maintenance-free if the technical limits are not exceeded

Absolutely backlash-free due to bolted connection.

Acceptable up to 1.5 times the value specified.

Custom designs with varied tolerances, keyways, non-standard material, bellows and ATEX designs are available upon request.

**Ordering example**

BK1/150 / 62 / XX

Model  
Series / Nm  
Overall length  
Non standard e.g. stainless steel

Model BK 1		Series																							
		15		30		60		150		200		300		500		800		1500		4000		6000		10000	
Rated torque (Nm)	T <sub>KN</sub>	15		30		60		150		200		300		500		800		1500		4000		6000		10000	
Overall length (mm)	A <sup>-2</sup>	30	37	36	44	43	53	50	62	53	65	56	70	64	77	81	100	145	138	150					
Outer diameter of bellows (mm)	B	49		55		66		81		90		110		124		133		157		200		253		303	
Fit length/thread depth (mm)	C	7.5		10		11		13		14.5		15		16		18		22		30		30		36	
Inner diameter H7 (mm)	D	25		28		38		50		58		65		70		75		85		100		145		190	
Fastening threads 6x	E	6 x M5		6 x M5		6 x M6		6 x M6		6 x M6		6 x M8		6 x M8		6 x M10		6 x M16		6 x M20		8 x M20		8 x M24	
Hub bolt circle ± 0.2 (mm)	F	35		37		46		62		70		80		94		90		110		140		190		234	
Outer diameter f7 (mm)	G	49		55		66		81		90		110		122		116		140		182		235		295	
Moment of inertia (10 <sup>3</sup> kgm <sup>2</sup> )	J <sub>total</sub>	0.07	0.08	0.14	0.15	0.30	0.32	0.90	0.95	1.30	1.40	1.95	2.10	3.0	3.4	4.3	10.6	46	132	350					
Approx. weight (kg)		0.15		0.2		0.3		0.6		0.8		1.35		1.8		1.9		3.3		8.9		13.9		23.7	
Torsional stiffness (10 <sup>3</sup> Nm/rad)	C <sub>T</sub>	20	15	39	28	76	55	175	110	191	140	450	350	510	500	780	1304	3400	5700	10950					
axial  ± (mm)	Max. values	1	2	1	2	1.5	2	2	3	2	3	2.5	3.5	2.5	3.5	3.5	3.5	3.5	3.5	3	3				
lateral  ± (mm)		0.15	0.2	0.2	0.25	0.2	0.25	0.2	0.25	0.25	0.3	0.25	0.3	0.3	0.35	0.35	0.35	0.35	0.4	0.4	0.4				
angular  ± (degree)		1	1.5	1	1.5	1	1.5	1	1.5	1	1.5	1	1.5	1	1.5	1.5	1.5	1.5	1.5	1.5	1.5				
axial spring stiffness (N/mm)	C <sub>a</sub>	25	15	50	30	72	48	82	52	90	60	105	71	70	48	100	320	565	1030	985					
lateral spring stiffness (N/mm)	C <sub>r</sub>	475	137	900	270	1200	420	1550	435	2040	610	3750	1050	2500	840	2000	3600	6070	19200	21800					

(1Nm ≅ 8.85 in lbs)